

## Mist Disinfection Machine

Raja M, Ajithlakshman M, Kasiraman S, Bharathwaj SR

Department of Computer Science and Engineering, Kalasalingam Academy of Research and Education, Krishnankoil, Tamilnadu, India

\*Corresponding author: Kasiraman S, Department of Computer Science and Engineering, Kalasalingam Academy of Research and Education, Krishnankoil, Tamilnadu, India. Tel: 9789722506, Email: kasiraman741@gmail.com

Raja M, Krishnankoil, Tel: 97873 21234, Email: mraja@klu.ac.in

Bharathwaj SR, Tel: 6380 053 043, Email: bharathwaj18032001@gmail.com

Ajithlakshman M, Tel: 6380 664 072, Email: ajithlakshman25@gmail.com

Received Date: May 06, 2021 Accepted Date: May 24, 2021 Published Date: May 26, 2021

Citation: Raja M, Ajithlakshman M, Kasiraman S, Bharathwaj SR (2022) Mist Disinfection Machine. J Comput Sci Software Dev 2: 1-6

### Abstract

Since the onset of the COVID epidemic, it has been cautioned which you wash your hands several times in the afternoon. The troubles that may be due to losing water can cause extra problems than the epidemic itself. To help resolve this hassle right here we are designing a system that gives hand washing while much less than 95% water is used. Occasional disinfection is a very essential thing in combating the epidemic. however, it absolutely requires so much water to kill germs on your arms. additionally, most of the people sincerely grow to be washing their palms (extra than 15- 20 seconds with a complete tap eliminated). Disinfecting without a doubt simplest desires water to reach every millimeter on your hand in addition to disinfectant or soap and ought to be just enough to kill any dirt or help it get out of your hand. when we turn on the tap only 10 - 30% water affects our skin and the relaxation simply flows over this primary layer of water.

Our device is shifting ahead to some other stage to permit you to keep more water than the usage of a fog-primarily based machine. The product is attached to the tank below it. The tank is filled with water and any safe disinfectant liquid if required. while the user rubs the soap on his arms and putsthem on the device, this automatically opens a water fog gadget that turns water in the tank into a mist and drives them into the bathroom.

Now the fog has the ability to detect all the corners of the hand in less than six seconds as it is far within the shape of gasoline (water vapor). After 5-15 seconds of publicity to the water, the cleaning soap in the user's hand is washed with a mist. This calls for less than 95% of the water to beable to be required for normal faucet-based hand washing. The gadget contains an air-conditioning fan needed to blow the mist into the washroom.

**Keywords:** Disinfection

## Introduction

This project fights the corona virus epidemic in regular handwashing and keeping public areas clean, reconsidering the insignificant intrusion into the result in water regular hand washing and control steps. Lives of residents to protect access to water use. When the user the hand is placed somewhere on the machine, is activated automatically, turning water into a reservoir be ineffective and direct to the bathroom. When liquids evaporate at the end of resonator also cools when in contact with cold ambient in the air, it forms ultra fine aerosols and creates a viscosity a thick cloud of mist. Solutions for clean oils or liquids in part glycol are particularly suitable. DC The fan is machine operated to drive and deliver fog produced in the hand room. Here we use ATMEGA328P, high performance, low power control from Microchip.

The handwashing gadget is powered through an Atmega-based manage gadget that permits guide settings. those settings encompass the time at which the gadget must blow the fog to each consumer. So our proposed gadget lets in handwashing to disinfect at an equal time while conserving extra water.

## Related Work

### Vivi Tri Widyaningrum

Vivi Tri Widyaningrum planned “Comparison of Automatic Water Taps Using Ultrasonic Sensors and PIR Sensors” The working principle of the two taps is the same, that is, the tap will open when an object (person) is found in front of the water tap.

### Hiral Surani

Hiral Surani. A planned a “Sensor Based Automatic Hand Sanitizer Dispenser” raises the view of a fully based sensor controlled by a sanitizer dispenser. This research paper represents a very different approach: we aim to automate the current process using other components of the system, thereby reducing product costs. Our self-designed self-propelled bumper can be used for sale to promote better sanitation in the community. The main advantage of this project is that we can design a number of automated providers in a short period of time using basic components on a very small budget.

## Hardware Requirements

- Atmega Controller
- Fog Maker
- Water Tank
- LCD Display
- DC Fan
- Keypad
- Piping
- Supporting Frame
- Buttons & Switches
- Screws & Bolts
- Resistors
- Capacitors
- Diodes
- IC's
- Transistors
- Connectors
- PCB

## Software Requirements

- Arduino ide
- MC Programming Language: C

## Structure and Components

### Mist maker

A smoke machine, smoke generator or smoke machine is a device that emits thick smoke similar to fog or smoke. This artificial fog is mainly used for professional recreational purposes, but smaller and cheaper smokers are often used for personal purposes. Smoking machines are also used for a variety of industrial, educational and military purposes. Mist is created by evaporating your own water and liquid, usually based on glycol or glycerin, or by spraying with mineral oil. This fluid (commonly referred to as colloquially as fog juice) is injected into a vacuum cleaner. When leaving the smokehouse and mixing with the external cooling liquid, the steam condenses and forms a thick, visible fog.

## IR Sensor

The IR sensor is an electronic component, which focuses on light detection coming in front of it. The objects coming nearby the sensor that will be easily detected by the IR sensor where we can keep the precision range according to our requirements.

## UV light

Ultraviolet radiation is part of an electromagnetic spectrum ranging from violet, or short wavelength, to the end of the visible light spectrum to the X ray region.

## Literature Review

Many creation technologies are proposed to mechanically create a sanitizing cleansing spray within the occasion of a deadly disease designed through the discovery of human motion [1]. Technology evolved by means of integrating an anti-septic door cope with with a cellphone to ensure that the home is supplied with right hygiene and disinfection [2]. and other smart devices linked to the internet [3]. The latest enlargement of IoT networks is designed to intelligently capture activities all through each epidemic and epidemic conditions [4]. demanding situations are effortlessly executed with the aid of the IoT as it integrates each cell and internet equipment and transmits

records speedy [5]. because the corona virus stays for extra than an hour on an object it is essential to construct greater automatic systemsto work higher in corporations wherein humans meet regularly. If left unchecked, it is able to spread to every age of humans at one-of-a-kind times. othercomputerized technology that work properly in epidemic conditions with the presence of small drones, IoT- primarily based hat for detection, clever glasses. And clever robots are still broadly disbursed to paintings in hospitals and talk with Covid's affected human beings. Abidet. al has designed an effective automobile wash gadget based on the size of the cloth. an automated hand sanitizer gadget that can be used for one of a kind boxes is designed. The demanding situations and issues posed through 2019-nCoV are analyzed. smart garb layoutand performance have implications for the current emerging context of clever clothing, their layout and performance.

## Proposed System

- Our machine is advanced to another level so that you can save more water using a fog-based system.
- our product is attached to the tank below it. The tank is filled with water and any safe disinfectant liquid if needed.
- When the user rubs the soap on his hands and puts them into the system, this automatically triggers a water spray system that turns the water in a tank into a mist and blows it into the washroom.

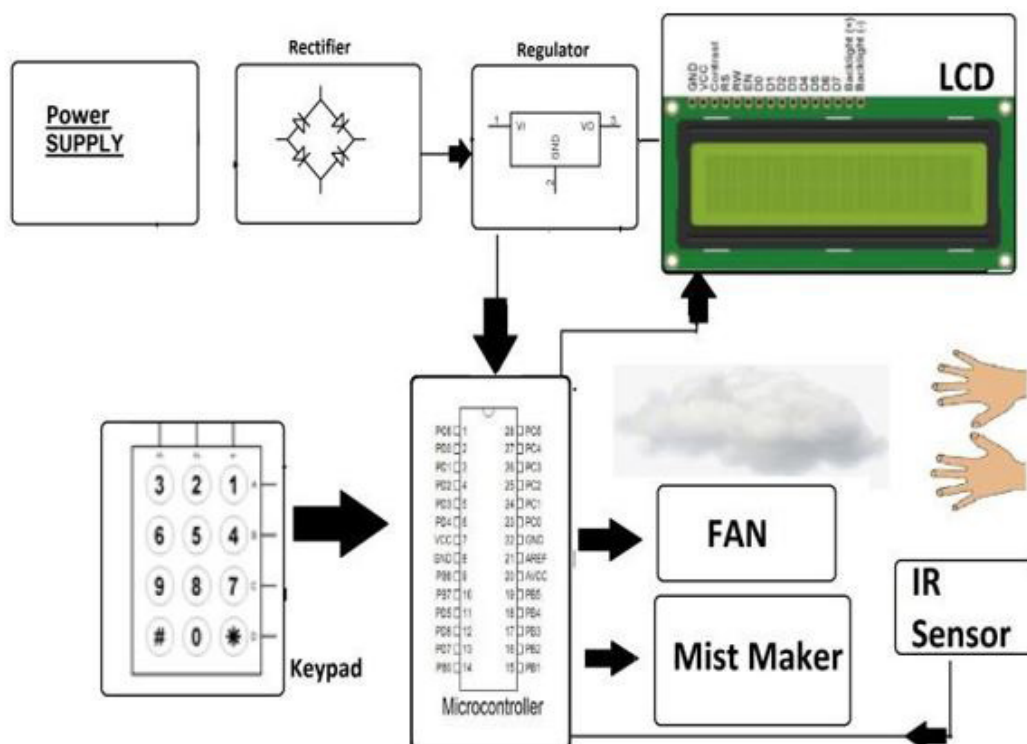

Figure 1: Block Diagram

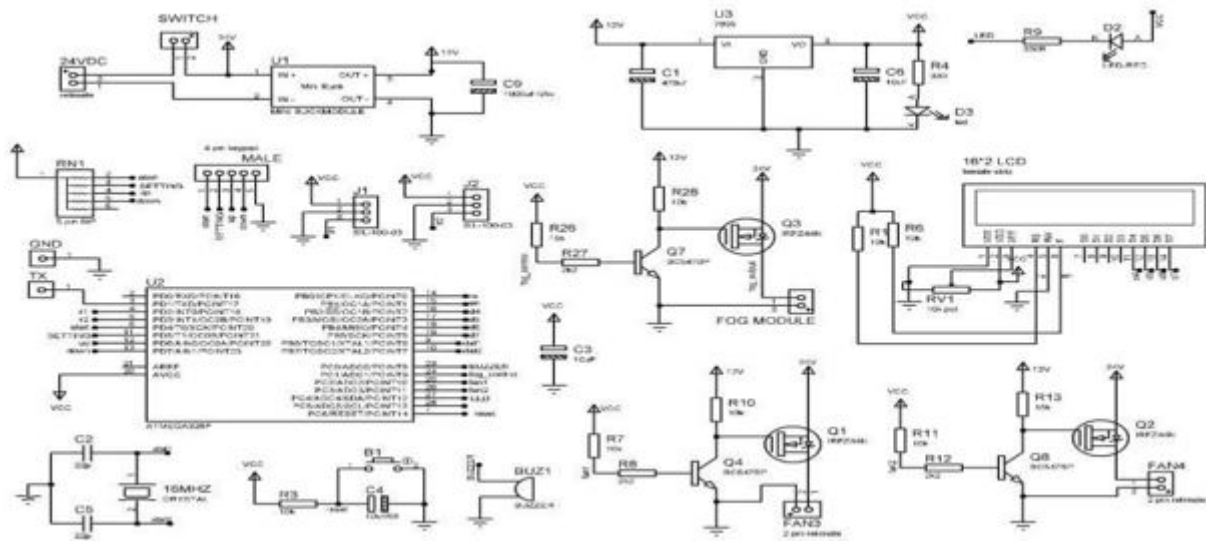

Figure 2: Circuit Diagram

### Experimental Setup

#### Methodology

- Fog maker used to convert a water into fog it operates on 5V.
- IR sensor used to detect the presence of hand inside the machine it also operates on 5V
- Arduino ide is used for coding.



Figure 3: Experiment Setup

---

## Advantages

- Effective Hand wash
- Up to 90% Water Saving
- Easy to Use
- Automatic Operation
- UV Disinfection

## Conclusion

The proposed work has many important benefits as well helps kill germs and germs in public places such as train stations, airports and theaters. Cleanliness is good it helps as it is a non-communicative method that helps keep the appropriate distance in line with the norm standards. Its portable design makes it easy to install again use in different areas depending on your needs. The technology used is relatively new and very unstable. Using less than 95% water than traditional hands washing, solves very important water savings problems, which is why we see progress and innovation products on the market in the same way. Use less than 95% water is needed to wash your hands through regular taps. Stored water can be used for other purposes. The system works automatically again avoids manual errors such as tapping, tap leak and increase water savings. With this machine, installation and storage of existing material taps are no longer a problem, people can now use them comfortably, untouched and very clean.

Next to electronics it is important to make the modern era bigger, our work is one concept that can change the face of today's guide to reduce the water scarcity. The most important right of entry for most of these games provides a convenient way to secure the environment and Reduce the usage of chemical soap and hand wash.

## References

1. Arun M, Baraneetharan E, Kanchana A and Prabu S (2020) Detection and monitoring of the asymptomatic COVID-19 patients using IoT devices and sensors. International Journal of Pervasive Computing and Communications.
2. Gupta D, Bhatt S, Gupta M and Tosun AS (2021) Future smart connected communities to fight covid-19 outbreak. Internet of Things 13: 100-342.
3. Kumar K, Kumar N and Shah R (2020) Role of IoT to avoid spreading of COVID-19. International Journal of Intelligent Networks 1: 32-35.
4. Pandya S, Sur A and Kotecha K (2020) Smart epidemic tunnel: IoT-based sensor-fusion assistive technology for COVID-19 disinfection. International Journal of Pervasive Computing and Communications.
5. Shanthini M and Vidya G (2020) IoT-Based Smart Door Lock with Sanitizing System. Inventive Computation and Information Technologies: Proceedings of ICICIT 63.

**Submit your manuscript to a JScholar journal and benefit from:**

- § Convenient online submission
- § Rigorous peer review
- § Immediate publication on acceptance
- § Open access: articles freely available online
- § High visibility within the field
- § Better discount for your subsequent articles

Submit your manuscript at  
<http://www.jscholaronline.org/submit-manuscript.php>