

The Process of Maintenance and Assessment of The Universal Testing Material Machine H50KS

Ayman Abu Ghazal*

Jordan Atomic Energy Commission, Amman, Jordan

*Corresponding author: Ayman Abu Ghazal, Jordan Atomic Energy Commission, Amman, Jordan, Tel: 00962791802192, Email: gazal.ayman@yandex.ru

Received Date: September 21, 2020 Accepted Date: October 23, 2020 Published Date: October 26, 2020

Citation: Ayman Abu Ghazal (2020) The Process of Maintenance and Assessment of The Universal Testing Material Machine H50KS. J Mater sci Appl 4: 1-12.

Abstract

The main goal of this report is to show the steps of maintenance and testing of the universal material testing machine - H50KS, present in the material testing laboratory in Research Laboratories and Information Directorate - Jordan Atomic Energy Commission. Starting from the stage of collecting primary information about the device, then identifying technical problems, finishing with the initiation of the device, which includes getting successful results when conducting a set of experiments that include testing several samples of High-density polyethylene (HDPE). The universal testing machine is mainly used to study the mechanical properties of materials; based on the obtained results we can judge whether the material is suitable for industrial utility, or needs further improvements to its properties. The material testing machine is considered as one of the most essential devices that shape the core of any materials testing laboratory worldwide. Given the limited budget available, an approach with the minimum cost was necessary.

Keywords: Universal material testing machine; tensile testing; polymers; High-density polyethylene.

Glossary of terms [2]:

Tensile testing: A method of determining the behavior of materials subjected to uniaxial loading, which tends to stretch the material which is a metal. A longitudinal specimen of known length and diameter is gripped on both ends and stretched at a slow, controlled rate until rupture occurs. Also known as tension testing.

Specimen: The object being tested is often of standard dimensions or configuration, used for destructive or nondestructive testing. One or more specimens may be taken from each sample.

Strain: The amount of change in the size or shape of a body due to the applied force. Also known as nominal strain.

Tensile strength: The ratio of maximum load to the original cross-sectional area of material during tensile testing. Also known as ultimate strength.

Ductility: The ability of a material to deform plastically before fracturing.

Extensometer: An instrument used for measuring changes in length for a given gage length caused by application or removal of a force.

Gage length: The length of the portion of a specimen for which strain, change in length, or other characteristics are determined.

Elongation, percent: The extension of the uniform section of a specimen expressed as a percentage of the original gage length:

$$\text{Elongation, \%} = \frac{(L_x - L_0)}{L_0} \times 100$$

where L_0 is the original gage length, and L_x is the final gage length.

Brittle fracture: The Breakage of a solid accompanied by little or no macroscopic plastic deformation. Typically, brittle fracture occurs by rapid crack propagation with less expenditure of energy compared to ductile fracture.

Grips: Part of the specimen used for holding it between the fixed and movable members of the testing machine; can be either of the fixed or self-aligning type [3].

Yield point: The first point on a stress-strain curve at which an increase in strain occurs without an increase in stress.

Tensile stress-strain curve: A diagram on which values of tensile stress are plotted as ordinates against corresponding values of tensile strain as abscissas.

Introduction

A tensile testing machine is a special testing device designed for the purpose of performing static tests and determining the mechanical properties of materials under axial tension, compression, and bending within the technical capabilities of the machine. Structurally, the machine consists of a loading device (either hydraulic or mechanical) and measuring parts, that record the changes in the applied force and deformation on the tested sample (Figure1).

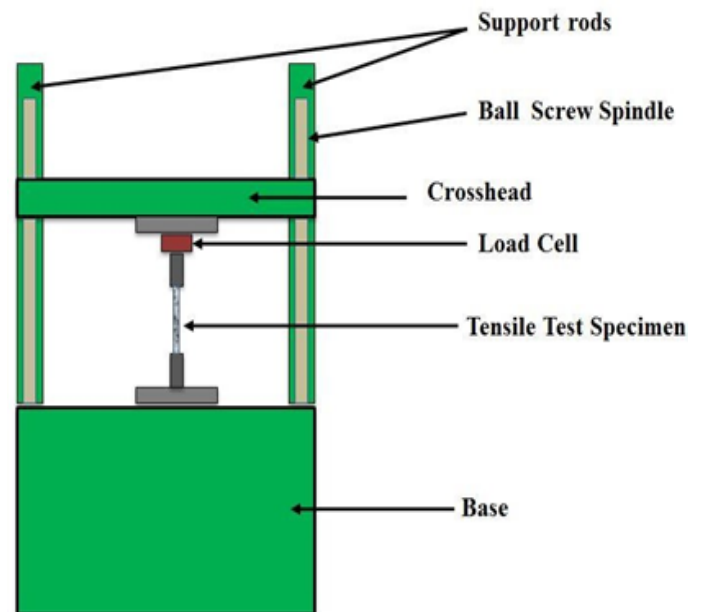

Figure 1: The main parts of the material testing machine.

Testing machines can be used at metallurgical plants, where constant quality control of the produced rolled metal is required; Similarly, in the nuclear industry, we are concerned with measuring the mechanical properties of the irradiated fuel element sheath and crack growth monitoring [1].

Tensile test results are useful in the selection of materials for engineering applications. For quality assurance, tensile strength characteristics are often included in material specifications. Tensile properties are often measured during the production of new materials and the development of new processes so that different materials and processes can be compared. Finally, tensile properties are often used to predict the behavior of a material under load types other than uniaxial tension. The strength of the material is often the main concern.

The strength of interest can be expressed either in terms of the stress required to cause noticeable plastic deformation or in terms of the maximum stress that the material can withstand. These strength measures are used precisely in engineering designs. Another parameter of interest is the plasticity of a material,

which is a measure of how much it can be deformed before it splits.

Ductility is rarely included directly in the design; rather, it is included in the material's specifications to ensure quality and strength. Low ductility in tensile testing is often accompanied by low fracture resistance in other types of loading. Elastic properties may also be of interest, but special methods must be used to measure these properties during tensile tests, and more accurate measurements can be made using ultrasonic methods [2].

Tensile testing machines are also known as universal testing machines. These machines hold specimens to be tested using grips that tightly hold each end. One grip keeps the material in place, while the other grip pulls until the tensile specimen ultimately break. Consider the typical tensile specimen shown in Figure 2. It has enlarged ends or shoulders for gripping as described earlier.

During the test, the specimen will slowly elongate at a standardized speed. The data collection software will record the material's test parameters, as well as the changes in the gage length. The software monitors the force being applied upon the specimen and display the stress-strain curve, which helps in the analysis of the specimen's behavior throughout the test.

General tensile test procedure according to ASTM D638 – 14 (Standard Test Method for Tensile Properties of Plastics)

1. Measure the width and thickness of each specimen to the nearest 0.025 mm:
 - Measure the width and thickness of the flat section at the center of each specimen and within 5 mm of each end of the gage length.
 - For the injection of molded specimens, the actual measurements of only one specimen from each sample will suffice when it has been previously demonstrated that the specimen-to-specimen variation in width and thickness is less than 1 %.
 - Measure the diameter of rod specimens, in addition to the inside and outside diameters of tube specimens, to the nearest 0.025 mm.
2. Place the specimen in the grips of the testing machine, with the careful alignment of the long axis of the specimen and the grips with an imaginary line joining the points of attachment of the grips to the machine. Tighten the grips evenly and firmly to the degree necessary to prevent slippage of the specimen during the test, but not to the point where the specimen would be crushed.

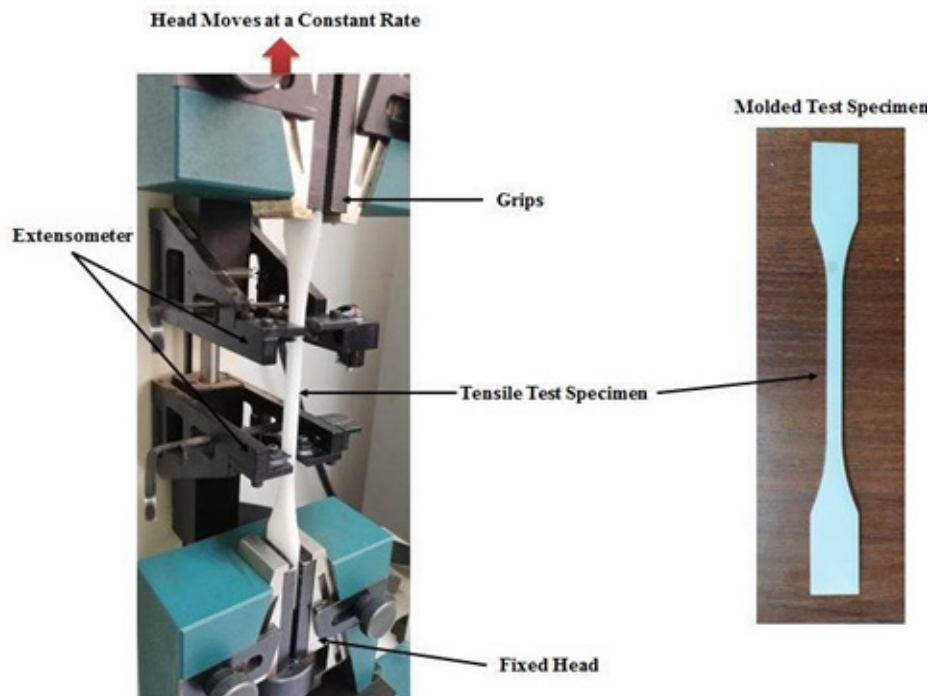

Figure 2: Typical tensile test specimen, showing a reduced gage section and enlarged shoulders

3. Attach the extension indicator.
4. Set the speed of testing to the proper rate, and start the machine.
5. Record the load-extension curve of the specimen.
6. Record the load and extension at the yield point (if any exists) in addition to the load and extension at the moment of rupture.

Technical problems of the machine

As mentioned earlier, this report is concerned with the stages of the rehabilitation of the material inspection device for the purpose of returning it into service and to verify the accuracy of the results after the repair process. The device was made in the United Kingdom by Hounsfield Company, and its specifications are shown in Table 1:

Manufacturer	Hounsfield U.K
Model	H50KS
Serial №	TX0187
Max .capacity	50 kilo Newton
Extensometer	100 R/S

Table 1: UTM machine characteristic

After checking the machine, the following problems were found:

1. The software of the tensile testing machine is missing due to the fact that the hard disk of the attached computer is damaged.
2. When turning on the machine, whether manually or automatically, and during the test, the machine suddenly stops working.
3. When connecting the Extensometer to the machine, an error message appears on the LCD screen of the machine (see Figure 3).

NOTE: Extension Indicator (extensometer): An instrument used

for determining the distance between two designated points within the gauge length of the test specimen as the specimen is stretched. Extensometer is used to measure the exact changes in the length of the tested sample [3]. This error appeared when the cable was connected between the extensometer and the port device screen. Note that the machine works normally when the cable of the extensometer is disconnected & the error disappears on the screen as shown in Figure 4.

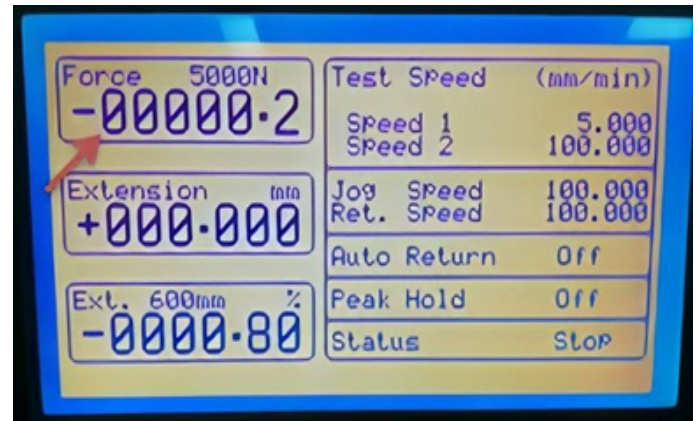

Figure 4: Shows how the error message disappears when disconnecting the cable.

Therefore, we conclude that the tensile testing machine H50KS is not able to perform any of the mechanical applications intended for it.

Progression through problem solving

A series of steps were followed to solve problems including collecting data, problem analysis, finding applicable solutions, testing, and stating conclusions.

It was found that the Hounsfield Company was acquired by Tinius Olsen Company about 15 years ago. And by communicating with the sales department of the company Tinius Olsen located in London, the device's software was requested for free.

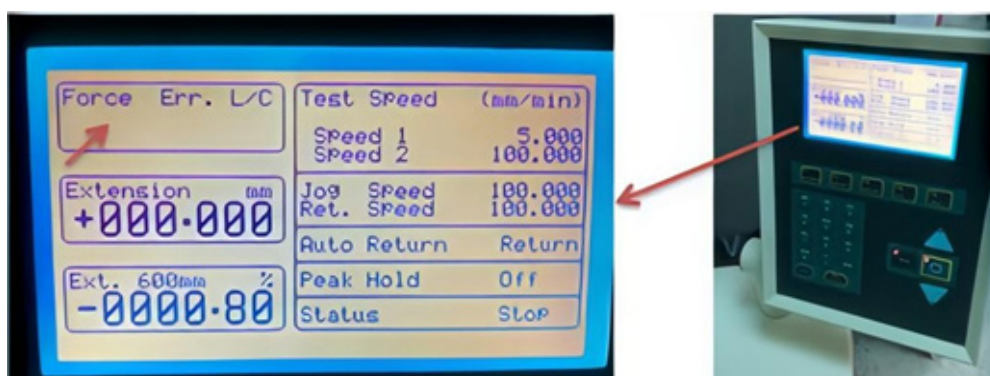

Figure 3: As seen, the tensile testing machine shows an error message (Err. L/C), indicated by the arrow

However, the response was that this software was no longer effective for a long time.

After disassembling and checking the machine, it was clear that the main cause of problem № (2) was the failure of the emergency button, moreover, bending in one of the control rods was found, which led to the application of excess load on the electronic parts within the machine. Finally, the damaged parts were replaced with new ones, costing 10 \$. See Figure 5.



Figure 5: In order to avoid any financial expenses, Eng. Diaa Ghassan (from the private sector) volunteered to solve the technical problems

Problem № (3) was clarified through communication with the Technical Support Department of Tinius Olsen company and it was concluded that there are two possibilities: failure of the cable connecting the extensometer to the machine, or damage to one of the parts of the Signal conditional interface card.

The company’s technical support department sent a copy of the electronic chart (see Figure 6) for use during the examination and identification of the damaged electronic parts.

After examining the cable, it was found that it is working well without any problems. Given that, the chance that one of the Signal conditional interface card parts is damaged becomes high. After testing, it was certainly found that both of the electrical fuses F1 and F2 (Fuse F LBC Quick Acting Mini 1 Amp 20mm×5mm) were damaged. The required parts were purchased for 5 \$. After being installed and reconnecting the extensometer to the machine, the error message (Err. L/C) disappeared, and readings appeared on the LCD screen.

The device was equipped with a laser printer, after being rehabilitated and repaired, to obtain printed results and depending on the LCD screen to show the results after performing the tests. Finally, it can be said that problem number one has been solved.

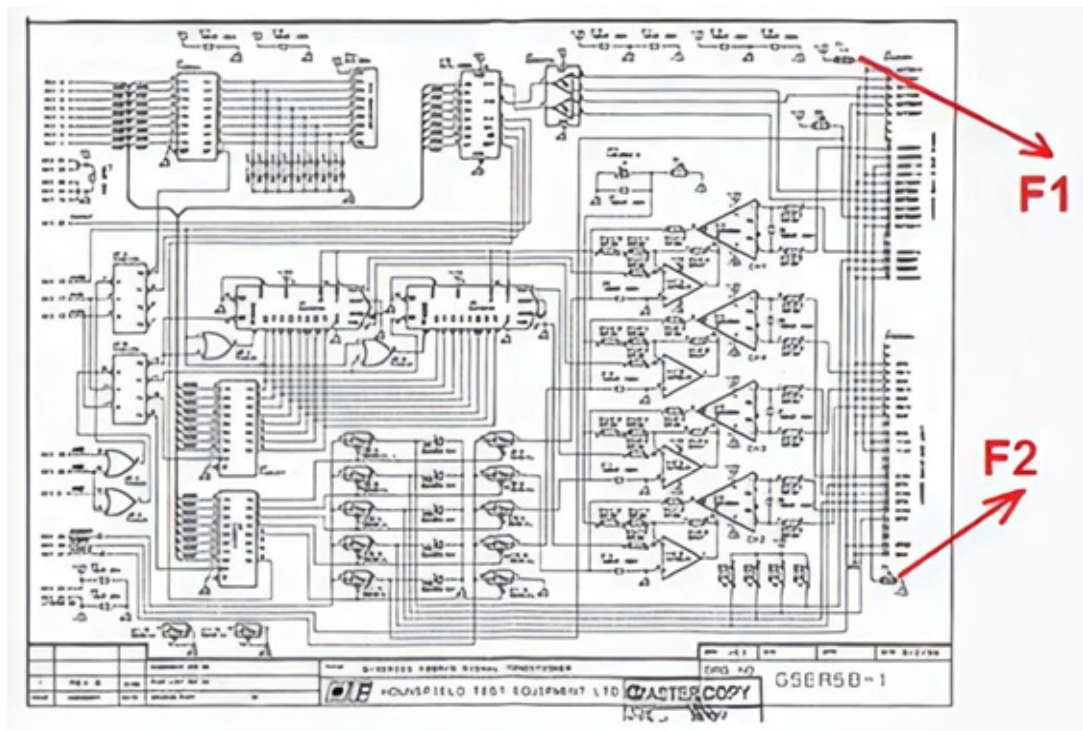

Figure 6: The electronic chart of the Signal conditional interface card, shows the damage electrical fuses F1 and F2

Outputs and Deliverables

The samples were prepared using an Automatic Hydraulic Press Machine, where a sheet of high-density polyethylene, Figure 7, was prepared from ore available in the laboratory. The ore form was exposed to a force of 30,000 pounds and heated to a temperature of 300 degrees Fahrenheit.

Using Specimen Preparation Punching Machine, a batch of samples was cut following ASTM D638, Figure 9. The

lack of other types of cutting dies was the only reason behind the reduced use of the second type of samples.

The results from the tensile test for both Sample №1 and Sample №2 are shown in Figure (10). We can notice from Figure (10) that the strength corresponding to the Yield point is approximately 600 Newton, which is equivalent to 28 MPa for Sample №1 and Sample №2 respectively.

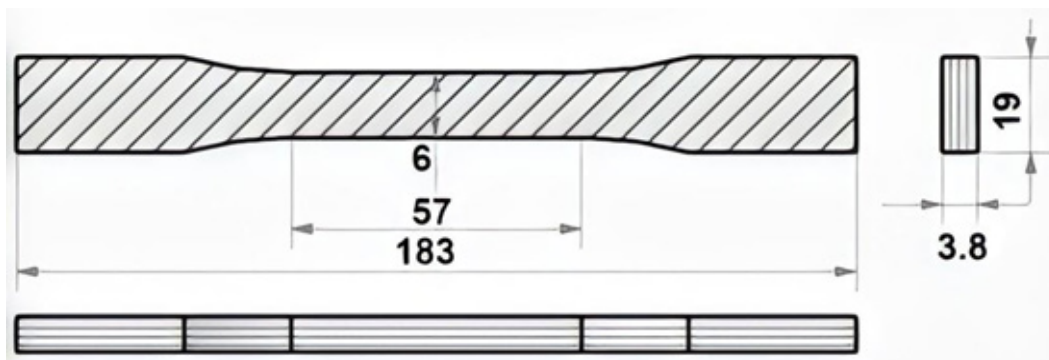

Figure 8: The geometric dimensions of type II sample according to ASTM D638

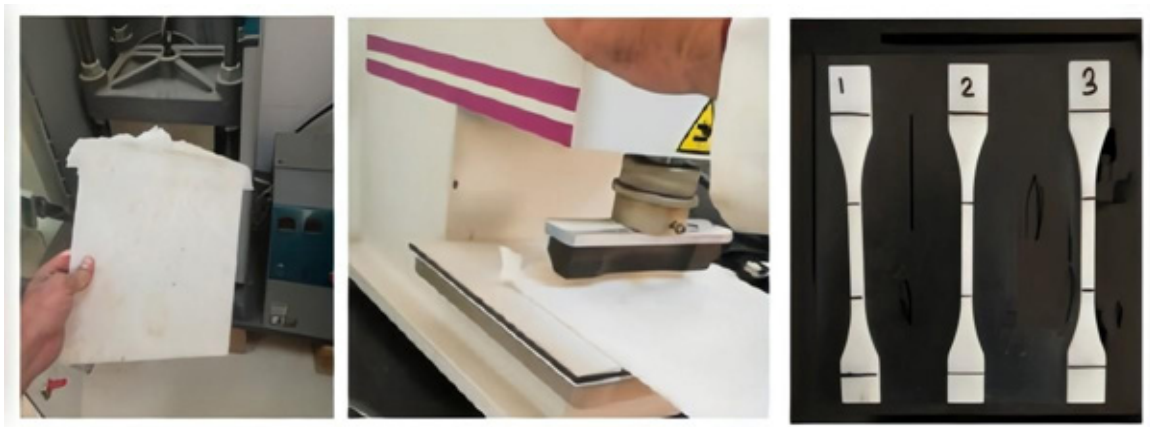

Figure 9: The preparation process of HDPE samples in the Materials Testing Laboratory

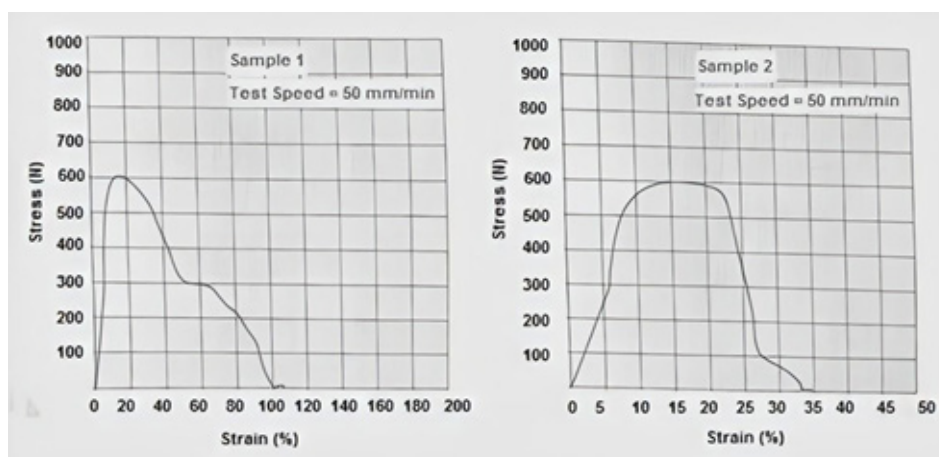

Figure 10: Tensile test results for HDPE samples (1 & 2) prepared in the Materials Testing Laboratory

The difference is clear in the values of Elongation at breakage, Sample №1 elongation ratio is approximately 100%, however, Sample № 2 elongation ratio reached approximately 35%. The behavior of the two curves is approximately the same, however, it does not correspond to the normal curve behavior that appears normally for such types of tests, see Figure 11, [4].

As it is known, there are several factors affecting the Elongation at breakage values [5]:

- Speed of Testing: Slow testing allows for polymer relaxation and higher elongation at break values
- Orientation Level: Fibers that are less oriented tend to exhibit greater degrees of elongation at breakage.
- Temperature: In general, elongation at breakage increases with an increase in temperature
- Filler Content: The elongation at breakage of composites decreases with an increase in the filler content

Several potential problems must be pointed out during the test set-up, including specimen misalignment and worn grips. The physical alignment for the two points of attachment for the specimen is essential because any off-center loading will exert a bending load on the specimen. This is critical in the testing of brittle materials and may cause problems even for ductile materials. The alignment will be affected by the testing-machine load frame, any grips and fixtures used, in addition to the specimen itself. Misalignment may also induce load-measurement errors due to the passage of bending forces through the load-measuring apparatus [2].

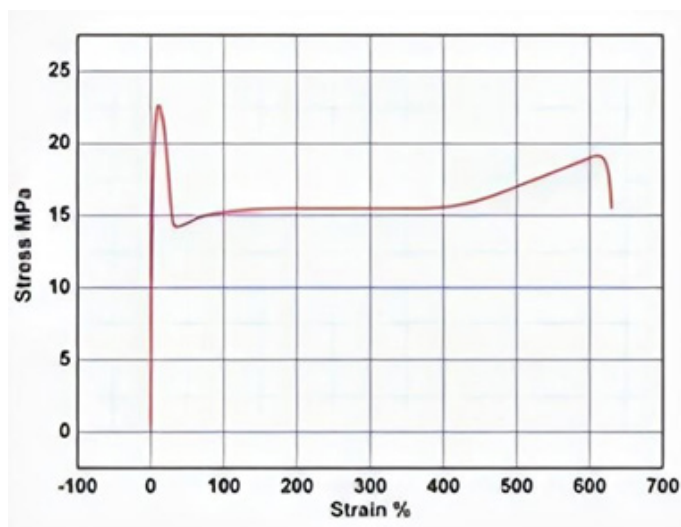

Figure 11: The typical Stress-strain curve of pure HDPE.

In literature [4] and [6], It can be seen that results from the tensile test for HDPE samples, containing defects of different lengths, which led to a decrease in ductility (Less ductile), affecting the nature of the fracture and making it less elastic, see Figure 12.

Comparing the obtained tensile test results from both Samples №1 & №2, we can see that they behave similarly and match the results from samples of HDPE material containing different cracks.

We Conclude that the preparation process of the polymer sheet in the laboratory was not done properly, which led to heterogeneity in the final sheet from which samples 1&2 were cut, due to the formation of internal defects (gas bubbles), see Figure (13), which in turn, affected many factors during the test, of which caused the samples not to undergo enough elongation, achieved by pure HDPE samples shown in Figure (11).

A new sheet was re-prepared correctly by consulting the chemical engineer Sewar Aljarrah from the Jordan University of Science and Technology to get the optimum preparation method to avoid any of the mistakes in the previous experiment.

Figure 14 shows the new tensile test results for HDPE Samples 3&4, we can see clearly that the Strength at Yield is approximately 580 Newton, which is equivalent to 27 MPA for both samples 3&4, The Elongation as a percentage is approximately 328% and 240 % for samples 3 and 4, respectively. The curve behavior for both samples is very similar, considered valid, and corresponds to the normal curve behavior of the tensile test in such type of testing, see Figure 11.

Table (2) presents a summary of the tensile test results for a group of HDPE samples prepared and tested in the laboratory using the Tensile testing machine H50KS, where the main focus was on presenting the values of Elongation at breakage & Stress at a yield.

Figure 15 shows the result of the tensile test sample № 12, as shown from the curve, we note that the sample reached enough elongation (796%) and how clearly the curve behavior satisfied the normal curve of HDPE polyethylene, Figure (11).

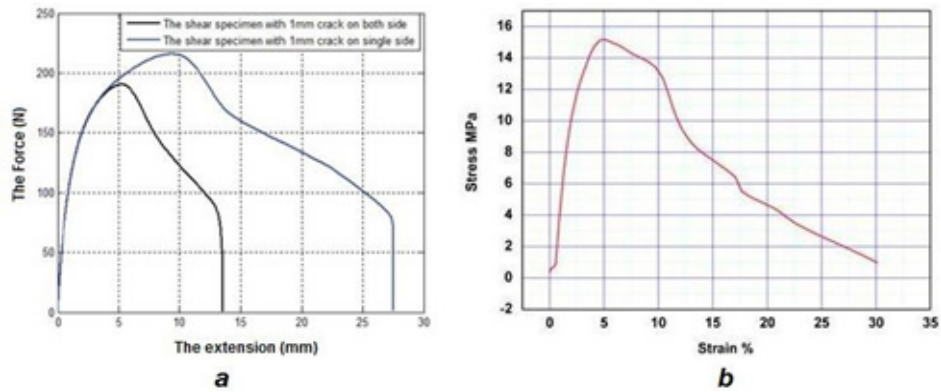

Figure 12 (a): Stress-Strain Curve for HDPE samples with 1mm cracks (b): Stress-Strain curve for pure HDPE sample containing a single crack.

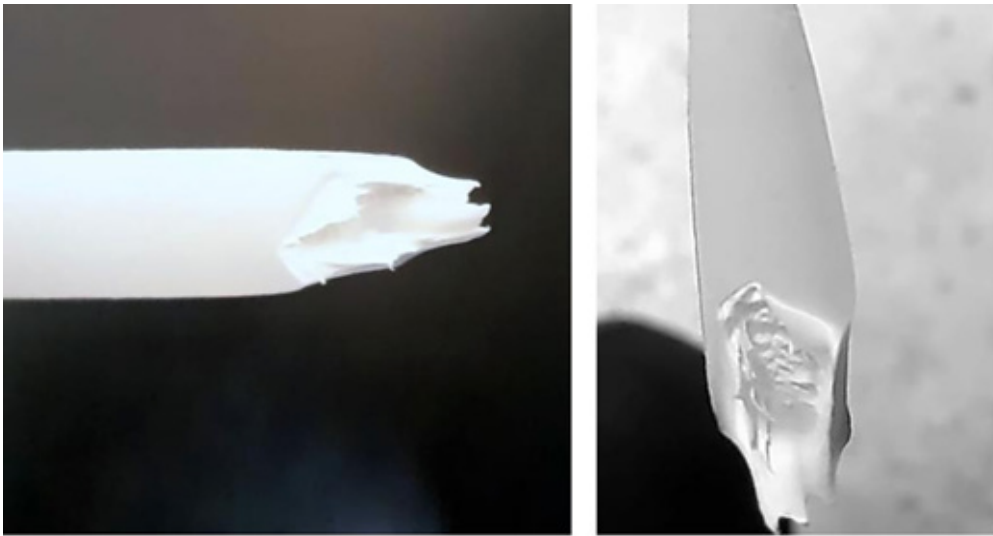

Figure 13: Images taken by a micro-camera showing the gas bubbles in the rupture area after the end of the tensile test for samples 1&2, prepared in the Material Testing Laboratory.

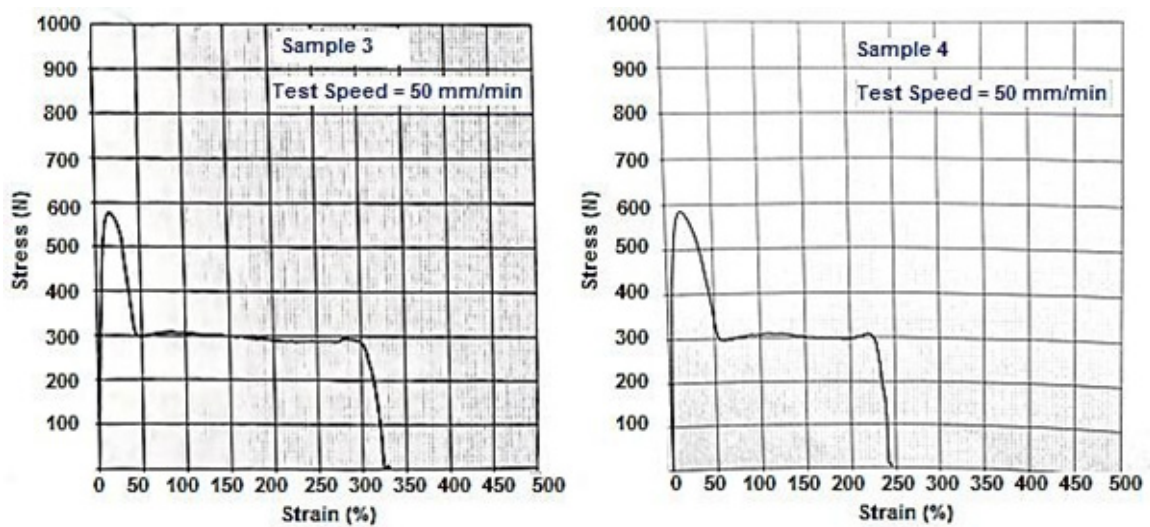

Figure 14: Tensile test results for HDPE samples 3 & 4, prepared in the Materials Testing Laboratory

Tensile Mechanical Properties	№1	№2	№3	№4	№5	№6	№7	№8	№9	№10	№11	№12	Reference Values ^[7] Min – Max
Elongation at breakage (%)	100	35	328	240	380	100	735	47	90	751	800	796	3.00 - 1900
Stress at yield (MPa)	28.0	28.0	27.0	27.0	19.0	28.0	17.0	27.0	21.0	20.0	27.0	52	2.69 - 200

Table 2: Tensile mechanical properties for a group of HDPE samples

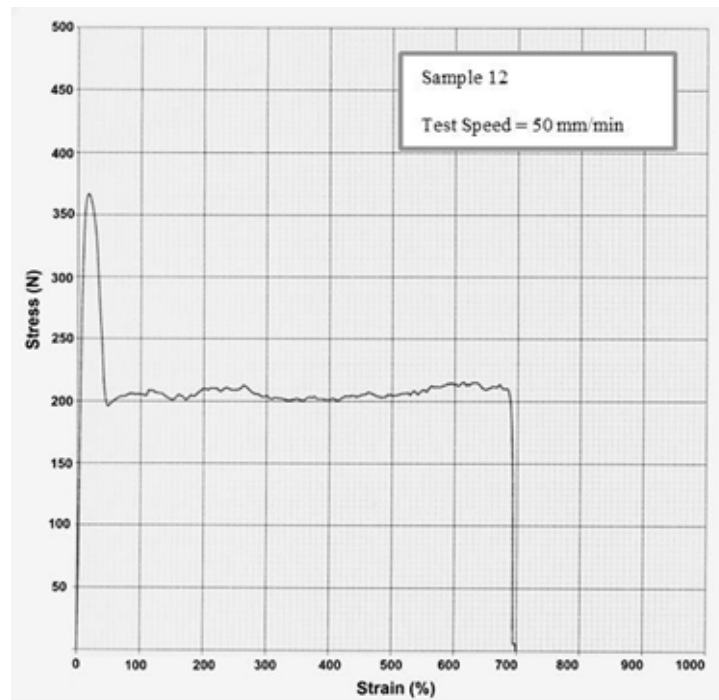

Figure 15: Tensile Successful test for HDPE sample № 12, prepared and tested in the Materials Laboratory by tensile testing machine H50KS.

Conclusions

1. All three technical problems concerning the material testing machine H50KS were successfully solved using minimum financial costs, given the limited capabilities, following the experimental Scientific methodology based on research, consultation, and volunteer work.
2. Samples (№5-№12) in table 2 were tested under the same conditions as samples 1,2, 3 & 4. We can notice that for some samples, elongation reached 1000% while others did not exceed 50%, depending on the factors mentioned previously.
3. Results for all HDPE samples prepared in the material testing laboratory and tested, using the tensile test machine H50KS after maintenance, satisfied with acceptable range values published in the international database [7].

Next steps

1. The Main accomplishment throughout the maintenance process done, is that the Tensile Testing Machine (H50KS) went through a process of maintenance with very limited resources and negligible cost, resulting in a machine used in testing samples giving acceptable results, all from scratch.
2. Testing the repaired Tensile Testing Machine (H50KS) using various reference samples including samples of Stainless steel, Carbon steel, Aluminum, Copper, and Lead. The purpose behind this is to test the machine's performance on different metal samples.
3. Development and redesign of the machine's grips were used to handle the sample from both sides during the test. The goal of such modification is to make the machine capable of handling samples of different shapes, such as cylindrical samples.
4. Development of a new system, including both hardware and software, used for the monitoring of polymer samples (such as Polyethylene) during the process of Tensile testing.
5. Exhibition of a future plan to follow according to the international standards developed for the acquirement of the ISO certification from the International Organization for Standardization, if acceptable results continue to be collected using the machine from different samples.

6. Making the Tensile Testing machine, located in the Materials Testing Laboratory, available for scientific research by students or researchers in general, thus making it available for commercial use.

Acknowledgement

Special thanks to Eng. Sara A.Rahim AlKhdour from the Nuclear Engineering Department from Jordan University of Science and Technology for proofreading and editing the report to ensure it is grammatically correct.

References

- 1) International Atomic Energy Agency. (2007). Characterization and testing of materials for nuclear reactors: Proceedings of a technical meeting held in Vienna, May 29--June 2, 2006.
- 2) Davis, J. R. (2004). Tensile testing (2nd ed.). ASM International.
- 3) D638 – 14. Standard Test Method for Tensile Properties of Plastics. 10.1520/D0638-14. Page 3.
- 4) El-Sheikhy, Refat, & Al-Shamrani, Mosleh. (2015). On the Processing and Properties of Clay/Polymer Nanocomposites CPNC. Latin American Journal of Solids and Structures, 12(2), 385-419. <https://dx.doi.org/10.1590/1679-78251399>.
- 5) Elongation at break or fracture strain: Technical properties of plastics. (n.d.). Plastic Materials | Free Online Database for Plastic Industry. <https://omnexus.specialchem.com/polymer-properties/properties/elongation-at-break>
- 6) Shaofeng Li, Kang Qi. The Mechanical and Fracture Property of HDPE-Experiment Result Combined with Simulation. Master's Degree Thesis ,ISRN: BTH-AMT-EX-a-2014/D07—SE, Blekinge Institute of Technology Karlskrona, Sweden ,2014.
- 7) MatWeb - The online materials information resource. (n.d.). Retrieved from <https://www.matweb.com/search/DataSheet.aspx?MatGUID=482765fad3b443169ec28fb6f9606660&ckck=1>

Submit your manuscript to a JScholar journal and benefit from:

- ❏ Convenient online submission
- ❏ Rigorous peer review
- ❏ Immediate publication on acceptance
- ❏ Open access: articles freely available online
- ❏ High visibility within the field
- ❏ Better discount for your subsequent articles

Submit your manuscript at
<http://www.jscholaronline.org/submit-manuscript.php>